

## APPLICATION NOTE

### Ground Fault Protection Testing per NEC 230.95(C) of Low Voltage Circuit Breakers

*This application note will cover why primary injection is specified per NFPA70/NEC standards, the basics of Ground Fault (GF) testing, and the challenges associated with testing Low Voltage (LV) circuit breakers using primary injection such as cable length, power sources, breaker configurations, and Current Transformer (CT) polarity.*

#### **NEC 230.95(C) Ground Fault Protection of Equipment**

In 2017 there was a change to NFPA70/NEC 230.95(C) Performance Testing, stating that the ground fault protection system shall be tested using a process of primary current injection for newly installed ground-fault protection systems.

Previously in the NFPA70/NEC 2014 Edition, NEC 230.95(C) stated that the test shall be conducted in accordance with instructions that shall be provided with the equipment. Often times this left the testing method up to the installer who may or may not have familiarity with how to properly test or install the ground fault protection system.

#### **What is Primary Injection Testing and what method was previously used?**

Primary Injection is the test method of applying an AC current through the primary side of the application. Typically, this would refer to passing a high current through the primary coil of a current transformer, which in turn is passed through the secondary coil(s) lowering the current to a level that can be handled by the protection device. With this method of testing you are testing the breaker contacts, current sensors, wiring, and trip unit for a **COMPLETE** test.

Secondary Injection is the test method of applying an AC current on the secondary side of the current transformer and essentially testing only the trip unit logic. In order to conduct this test, you would need to have the manufacturer's specific secondary test kit, or be able to access the secondary side of the current transformer. *(There are various manufacturers of Trip Units and some may use an AC voltage, AC current, or a DC voltage as the secondary injection means of testing the trip unit.)*

As you can see, the previous testing method per NEC 230.95(C) 2104 would have allowed for testing the breaker utilizing a secondary injection method, pressing the trip test button, or simply not testing the ground fault protection at all. Granted the secondary injection test method can be a time saving approach when utilizing manufacturer's test kits, it also shows that you are not getting a complete test of the ground fault protection circuit of the breaker.

## APPLICATION NOTE

### Ground Fault Protection Testing per NEC 230.95(C) of Low Voltage Circuit Breakers

#### Basics of Ground Fault Protection

There are several different methods of detecting ground faults on LV circuit breakers. Residual Sensing 3 Pole or 4 Pole, Residual Sensing 3 Pole with External Neutral CT, Zero Sequence, and Source Ground Return (Figure 1). Some manufactures may use different terminology for similar methods.

- Residual Sensing – Also known as Integral Ground Fault Sensing can be setup as 3P, 4P, or 3P with an external neutral CT. Utilizes vectorial summation of the currents on each phase and neutral if applicable using separate CT's in order to determine a possible path to ground. If the system has a balanced load, then the resulting current flow through the GF Protection circuit would be equal to 0. ( $I_a + I_b + I_c + I_n = 0 = \text{No operating current}$ ) This method detects faults downstream of the circuit breaker
- Zero Sequence – Similar to residual sensing where the vectorial summation of the currents is monitored, but instead of multiple CT's, there is only a single CT that encompasses all the phases including the neutral (if applicable) and is external to the circuit breaker.
- Source Ground Return – Utilizes a CT on the ground conductor and monitors for any ground current that is returning to the source. Detects faults both upstream and downstream of the circuit breaker.

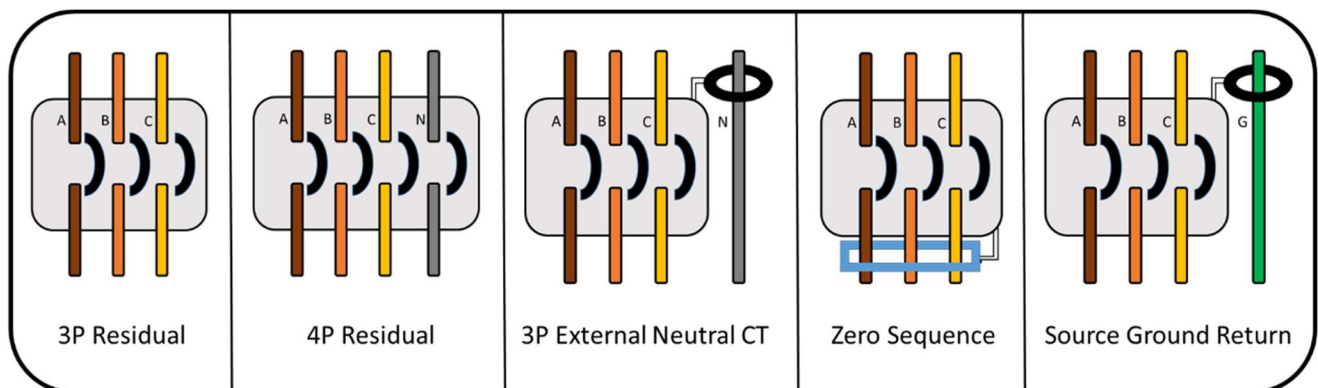

(Figure 1) Ground Fault Detection Methods on Low Voltage Circuit Breakers. 3 Pole Residual, 4 Pole Residual, 3 Pole Residual with External Neutral CT, Zero Sequence, and Source Ground Return.

## APPLICATION NOTE

### Ground Fault Protection Testing per NEC 230.95(C) of Low Voltage Circuit Breakers

#### Testing Procedures of Ground Fault Testing

For the purpose of this application note the two most common GF configurations (3P Residual Sensing and 3P Residual with External Neutral CT) will be explained in detail. **\*\*These are general guidelines for Ground Fault testing. Please refer to manufacturer's recommended procedures for specific testing sequences\*\*.**

There are several tests that need to be conducted in order to ensure the Ground Fault Protection is installed and operating correctly.

- Trip Test – A trip test ensures that pickup and timing of the GF element in the trip unit is operating correctly in accordance with the manufactures Time Current Curve (TCC).
- No-Trip Test – A no-trip test ensures that the trip unit will not give a false trip, the CT's are phased and sized correctly and that the GF element is working correctly.
- External Neutral CT Phasing and Sizing – Units equipped with external neutral CT's may require additional testing if those elements are activated in the trip unit. CT phasing is used to determine that the CT and connections are terminated correctly and that the polarity is correct. CT sizing is used to ensure that the CT is sized to match the breaker CT's.

#### Trip Test - Residual Sensing 3P and 3P with External Neutral:

- 1.) Isolate the power source from the circuit breaker and follow all safety and lock out tag out protocol before connecting any test equipment. **This test is to be conducted on de-energized equipment only.**
- 2.) Record the breaker nameplate information.
- 3.) Record the trip unit pickup and delay settings of all the protection elements before making any adjustments.
- 4.) If the breaker is equipped with Zone Interlocking, this may need to be defeated before testing. **\*\*Refer to manufacturer's manual\*\*.**
- 5.) Set all Long, Short and Instantaneous settings = Max.
- 6.) Set GF Pickup = Min
- 7.) Set GF Delay = 0.2 or 0.3 (Setting to Min may cause a nuisance trip, as a slightly higher setting may be required for better timing accuracy depending on test equipment.)
- 8.) For 3P breakers with external neutral CT, you will need to conduct the CT phasing check and sizing before proceeding. (Refer to External CT Phasing and Sizing)

## APPLICATION NOTE

### Ground Fault Protection Testing per NEC 230.95(C) of Low Voltage Circuit Breakers

- 9.) Connect the test set with the “Output Lead” (aka Polarity Lead) connected to the line side of “A” phase of the breaker and the “Return Lead” (aka Common Lead) to the load side of the breaker (Figure 2).
- 10.) The “Pulse Method” is used to determine the pickup of the GF setting as it is more accurate than the “Run-Up” method. Current is applied starting at 70% of the expected trip value in 10,15, or 20 cycle pulses depending on the GF delay setting. Current is increased each pulse until the breaker trips or exceeds the accuracy percentage of the maximum trip current on the TCC.
- 11.) Reset the breaker and decrease the current per pulse if further accuracy is needed.
- 12.) Once the GF Pickup has been determined, the GF Delay will be tested by applying 150% of the GF pickup setting. Apply the current for longer than the GF delay setting. This can be accomplished by applying current in a “Continuous” mode.
- 13.) The trip time can then be compared against the TCC.
- 14.) Reset the breaker and repeat this process on “B” and then “C” phase.

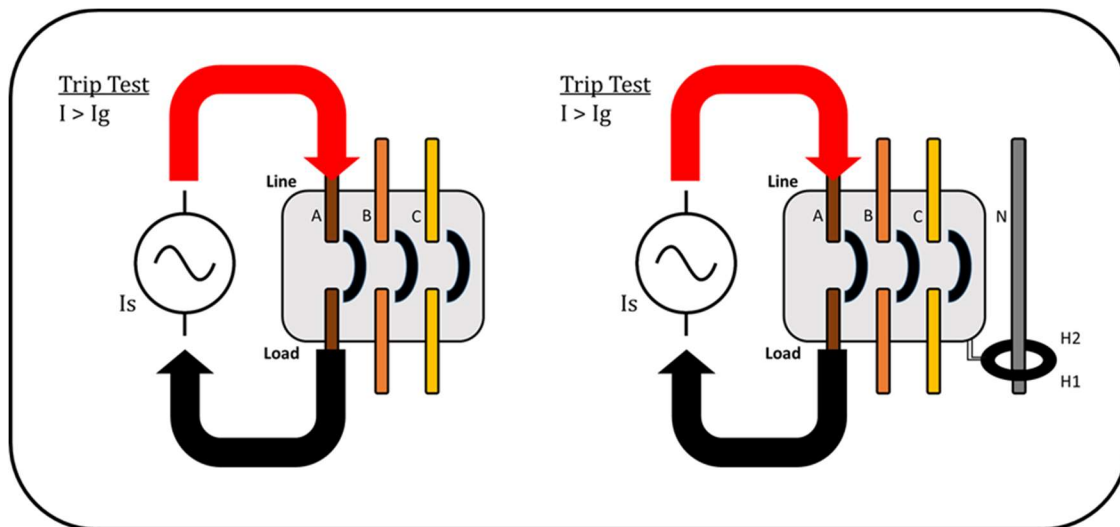

(Figure 2) Trip Test – GF Pickup is conducted by applying current from line to load of the breaker using the pulse method. GF Timing is conducted with the same connections using the continuous method. Current seen by the Trip Unit will be greater than or equal to the GF Pickup as expressed by ( $I > I_g$ ).

## APPLICATION NOTE

### Ground Fault Protection Testing per NEC 230.95(C) of Low Voltage Circuit Breakers

#### No-Trip Test - Residual Sensing 3P and 3P with External Neutral:

- 1.) After the Trip Test has been completed for the 3P configuration, the No-Trip Test can be conducted. (For 3P with External Neutral CT, the No-Trip Test is conducted during the CT Phasing.)
- 2.) Connect the "Output Lead" of the test set to the line side of "A" Phase and a jumper from the load side of "A" Phase to the load side of "B" Phase. Connect the "Return Lead" to the line side of "B" Phase (*Figure 3*).
- 3.) Apply 125 -150% of GF pickup setting for longer than GF delay. (Ex. GF PU = 500A and GF DELAY = 0.3 seconds. Test could be conducted @ 750A for 10 seconds.)
- 4.) Breaker should **NOT** trip. No trip indicates that CT's are phased properly and the trip unit is responding correctly.
- 5.) Repeat the process on Phases B to C and C to A.

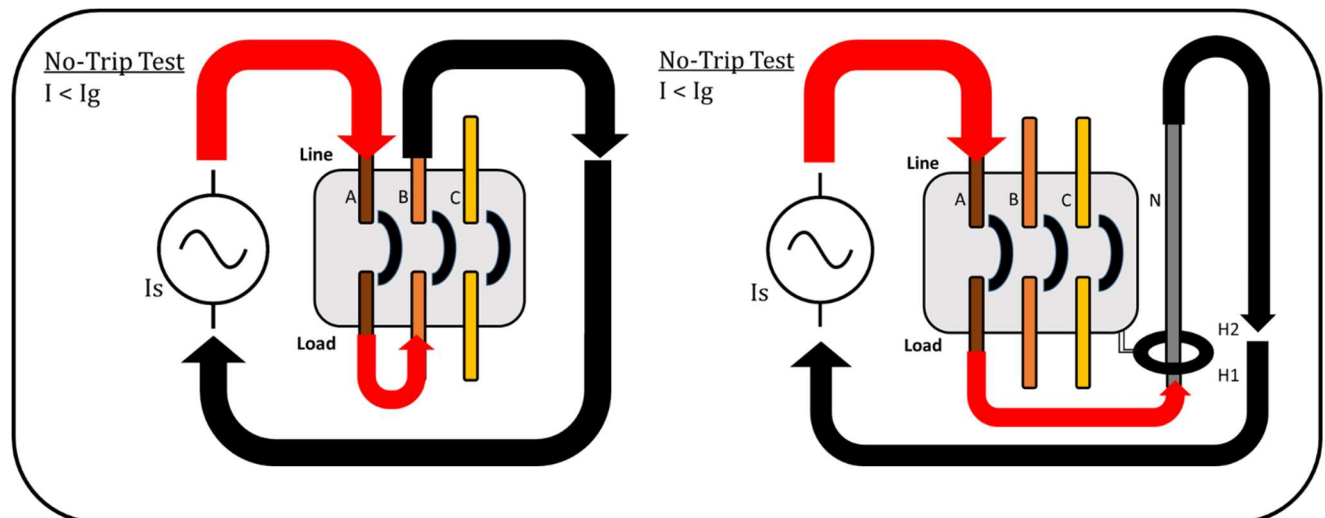

(Figure 3) No-Trip Test and External Neutral CT Phasing is conducted by applying current from line to load and returning the current through another phase or neutral back to the source. This results in a vector cancellation of the current as it pertains to GF pickup. Current seen by the Trip Unit will be less than the GF Pickup as expressed by  $(I < I_g)$ .

### Ground Fault Protection Testing per NEC 230.95(C) of Low Voltage Circuit Breakers

#### External Neutral CT Phasing and Sizing – Residual Sensing 3P with External Neutral CT:

- 1.) The External Neutral CT Phasing and Sizing is conducted to ensure that the CT Polarity and Ratio are correct for the application. (Procedure may need to be modified depending on the polarity of the internal breaker CT's.)
- 2.) Connect the "Output Lead" of the test set to the line side of "A" Phase and a jumper from the load side of "A" Phase to the H1 side of the Neutral CT. Sometimes the CT will be noted with a white or red dot that helps denote the H1 side of the CT. Connect the "Return Lead" to the H2 side of the CT (*Figure 3*).
- 3.) Apply 125 -150% of GF pickup setting for longer than GF delay. (Ex. GF PU = 500A and GF DELAY = 0.3 seconds. Test could be conducted @ 750A for 10 seconds.)
- 4.) Breaker should **NOT** trip. This will indicate that the Circuit Breaker CT and the Neutral CT are properly phased.
- 5.) If the breaker does trip, then the following will need to be verified: Neutral CT orientation, trip unit settings, Line/Load termination configuration, and wiring.
- 6.) Sizing of the CT should be performed in order to ensure that the External Neutral CT is properly sized with the internal breaker CT's for correct ratio.
- 7.) Connect the "Output Lead" to the load side of "A" Phase and a jumper from the line side of "A" Phase to the H1 side of the Neutral CT. Connect the "Return Lead" to the H2 side of the Neutral CT (*Figure 4*).
- 8.) With this configuration, the current being sensed by the trip unit should appear as double the injected current and trip the circuit breaker at half of the trip unit setting. Using the Pulse Method as described in the Trip Test, the pickup value should be found to be half of the trip unit setting. (Ex. GF PU = 500A. Current injected approaching 250A will look like 500A to the trip unit if the ratios are matched between the External and Internal CT's.)

## APPLICATION NOTE

### Ground Fault Protection Testing per NEC 230.95(C) of Low Voltage Circuit Breakers

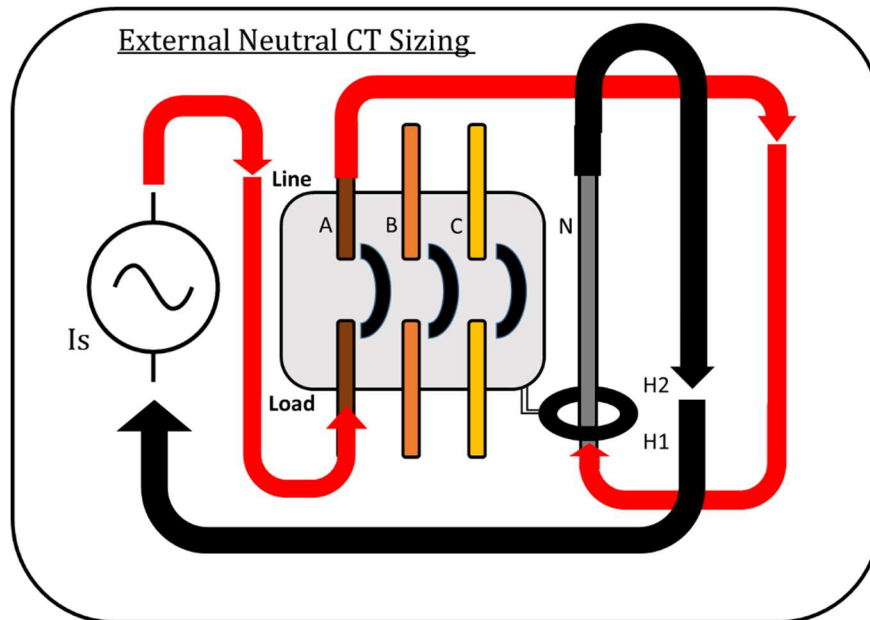

(Figure 4) External Neutral CT Sizing is required in order to determine if the CT in the circuit breaker and the External Neutral CT are sized to match. If the CT's have different ratios, then the current metering will be unbalanced and the trip unit may trip the breaker inaccurately. Breaker should trip at half the current of the trip unit settings; due to the trip unit seeing the current as doubled in this configuration.

#### Field Testing Challenges

There are a number of challenges may be encountered when field testing any apparatus. Primary Injection testing can pose its own unique challenges that will be addressed below. This is by no means a detailed exhaustive list of all the challenges one might face, but it may be helpful in addressing some of the more common ones.

#### Power Sources:

Power source requirements for primary injection test sets can range from a 480V 400A capacity generator, down to a 120V 20A building outlet. Careful selection is required when it comes to selecting the right generator, transformer, or building circuit. While there are no one size fits all approach, there are some things to keep in mind.

## APPLICATION NOTE

### Ground Fault Protection Testing per NEC 230.95(C) of Low Voltage Circuit Breakers

- I. Harmonics – If you are using an instrument with solid state components or sensitive metering, then harmonics on the circuit can cause disruption to the controls. Keep circuits separate when it comes to server racks, high frequency radios, and VFD's to name a few.
- II. Generators – Not all generators are created equal. Whether you have a gasoline, diesel, or propane powered engine, there are limitations on the block loading of the engine and voltage regulator. When the generator is block loaded due to the instant request for large amounts of power output, the engine and excitation system now have to work harder to get the unit back to the proper frequency and voltage. If the unit cannot react sufficiently, then the output of the primary injection test set may be affected and possibly interrupt current flow temporarily and cause irregular test results. Some units may respond faster to block loading than others, and so it may be beneficial to only load the Generator to 50% of capacity.
- III. Inverters – Like Generators are not all created equal. Inverters come in different sizes, output wattage, and output quality. There are two basic designs, Modified Sine Wave and Pure Sine Wave. Modified Sine Wave units should not be used on sensitive electronics as the sine wave is more of a square wave signal and appears choppy at best on an Oscilloscope (*Figure 5*). Pure Sine Wave units produce a pure Sine Wave as the name states. The cost of a Pure Sine Wave unit is typically much higher than the Modified units, but are essential when it comes to sensitive electronics.

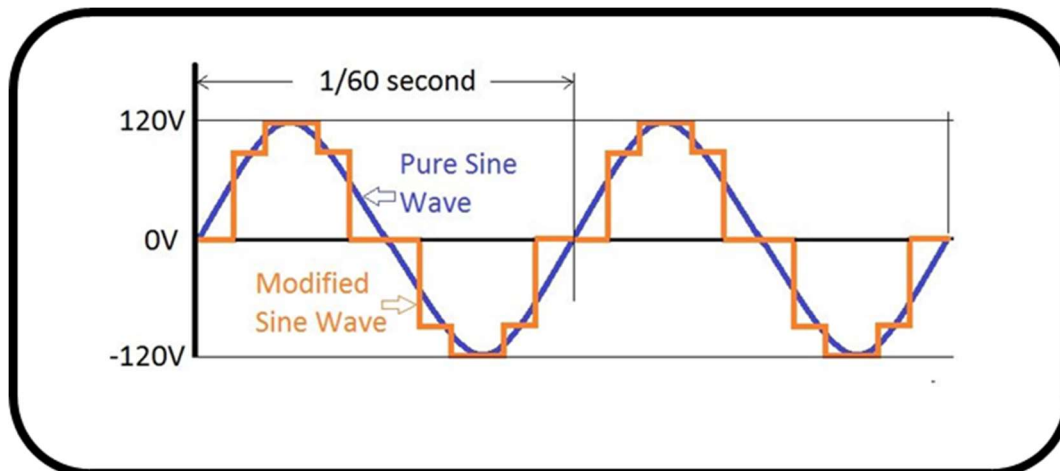

(Figure 5) Example of Pure Sine Wave vs Modified Sine Wave



### Ground Fault Protection Testing per NEC 230.95(C) of Low Voltage Circuit Breakers

#### Breaker Configurations:

There are multiple configurations of breakers from the connection method, construction, features, and trip units. Here we will cover just a few of the different elements that may be seen during ground fault testing.

- I. **Connection Method** – Circuit Breakers can be installed with busing or cabling, but they can also be terminated with the “feeding” to the “Top Side” of the breaker being “Line” or “Load”. Special attention must be taken to ensure the connections are made correctly during installation of the breaker and during testing, especially if an external neutral CT is utilized. Best practice would be to inject current from the “Line” to “Load” side of the circuit breaker. Verification of the internal breaker CT polarity maybe necessary when testing with an external neutral CT. There are factors that can also affect the connection method between the test set and the breaker during testing. These could include but not limited to cabling, busing, bolts, vise grips, or lugs. Special care is to be taken into consideration when using crimped cables and multiple lugs, as these connections can cause added impedance which will affect the output of the test set. Custom made cables and connection methods can be checked with a low resistance ohmmeter to verify a solid connection between the cable and the crimp before using in the field.
- II. **Classifications and Construction** – There are 2 main types of LV breakers that utilize ground fault protection. Molded Case circuit breakers and Power circuit breakers.
  - a. Molded Case Circuit Breakers (aka MCCB) are constructed of a molded insulating material and may use an electromechanical or electronic trip unit. The electromechanical trip unit will typically have both a thermal component and magnetic component.
  - b. Power Circuit Breakers use a combination of molded insulating material and a metal frame. Power Circuit Breakers will typically utilize an electronic solid state trip unit. Power Circuit Breakers are also available in fixed mount and rack-able.
- III. **Features** – Circuit breakers can have a number of accessories and features included on them that may or may not need to be disabled during breaker testing.
  - a. Thermal Memory – Power Circuit Breaker thermal memory monitors the current through the breaker poles and accounts for cable heating and required cooling before allowing the breaker to be reclosed. Each manufacture has a means of disabling this feature in the event that the 15-20 min wait period is not needed. Disabling may require a manufacturer’s specific secondary injection test set or jumpers. MCCB’s typically do not have a bypass means as the bi-metal (thermal

### Ground Fault Protection Testing per NEC 230.95(C) of Low Voltage Circuit Breakers

- component) bends during heating and requires proper cooling in order to release the trip mechanism and re-form its shape.
- b. Zone Selective Interlocking (ZSI) – Zone interlocking is used to communicate with upstream and downstream breakers in order to allow time for the proper breakers to trip. This feature may need to be disabled when testing breakers in order to eliminate any interference with the accuracy of the test, or effecting other breakers in the system that may be currently on-line. Disabling may require a manufacturer’s specific secondary injection test set or turning off functionality in the trip unit.
  - c. Under Voltage Coil – If the breaker is equipped with an under voltage coil, the breaker cannot be closed until the coil sees the proper voltage on the breaker. This coil will need to be disabled in order to conduct primary injection testing including ground fault testing. Disabling methods could include removal, or applying a mechanical interlock override tool that allows the breaker to be closed.
  - d. Maintenance Switch – Maintenance Mode switches have many names depending on the manufacturer, but the idea is that the switch can be turned on in order to reduce the arc hazard during maintenance of the circuit in which the breaker is connected to by lowering the trip settings to a safer working level. The switch may be controlling the breaker it is near, and/or a breaker up or down stream. Determining if the breaker you are working on is being controlled by a maintenance switch can be referenced in the manufacturers user manual. If the Maintenance Switch is turned on during the testing, then the results may not be accurate as the settings may have been changed as compared to where the manual dial settings are configured on the face of the trip unit. Keep in mind that the breaker may need an external AC or DC power source to activate this feature. Caution should be used when testing breakers that have external power supplies. **Primary injection is to be conducted on de-energized equipment.** Even with a de-energized breaker, there may be external power provided for trip unit power and other accessories.
- IV. **Trip Units** – Most trip units used today are Electronic or Solid State devices that are used to set a multitude of trip functionality to protect the breaker, loads, and personnel such as long term, short term, instantaneous, ground fault, and earth leakage. Depending on the trip unit installed, you may have some or all of these functionalities. It’s important to determine if the circuit breaker you are testing is equipped with ground fault sensing before getting setup to start testing. Most trip units will have a dial that can be used to set GF pickup and delay, or a menu item in the display that can be set to obtain the same settings. If the breaker you are planning to test does not have a dial on

### Ground Fault Protection Testing per NEC 230.95(C) of Low Voltage Circuit Breakers

the face of the trip unit or an option in the menu, then chances are that the unit is not equipped with ground fault sensing.

- a. External Power Sources – Some trip units can be powered up by an external AC or DC voltage. The AC or DC bus system in the switchgear may be powering the circuit breaker trip unit and accessories even when the breaker is de-energized. This can be utilized to verify or make changes to GF settings if needed before removing the breaker from service or racking the breaker out of the cell. Most manufacturer specific secondary injection test sets or external power supply accessories have the ability to power up the trip unit to check the settings or check the last recorded fault. Most trip units are self-powered when current is passing through the circuit breaker, but it may require 20% or more of the rated current before powering up. **\*\*Powering up the trip unit should not be required to conduct GF testing, but may be required to verify settings and last trip\*\*** If a manufacturer specific secondary trip unit is not available, then two primary injection test sets may be required in order to power up a single phase of the circuit breaker while testing another. Not a normal requirement, but may be needed if current metering on the trip unit and last trip are important for testing purposes, or the unit needs to be powered to change settings and there are no external power sources available such as the secondary injection kit.
- b. Secondary Injection Tester – Each manufacturer will have its own dedicated secondary injection test kit for their breaker trip units. These test sets can be used to conduct secondary injection testing, power up the trip unit, and disable features like ZSI, GF, and Thermal Memory. These can be great tools to assist with testing but in most cases are not required to perform GF testing.

#### Cable Length:

Bussing or cabling can be utilized for primary injection testing. The current requirement will dictate the best application of either options. Typically bussing is utilized for large breakers when high amounts of current are needed to perform primary injection of instantaneous and short time protection. Cables can also be utilized, but would require careful calculation for cross-section, numbers of cables, and length. Because this application note is focused on Ground Fault testing, cables are a more preferred method because of the flexibility and the max setting of Ground Fault Protection per NEC 230.95(A) is only 1200A.

## APPLICATION NOTE

### Ground Fault Protection Testing per NEC 230.95(C) of Low Voltage Circuit Breakers

Cable length is of equal importance to thickness and minimizing the length is going to reduce the total impedance of the circuit. Longer cables can lead to higher impedance, which reduces the voltage and thus the current cannot flow. Increasing the size or cross-section of the cable can assist in minimizing the impedance, but other steps can be taken to further reduce impedance and reactance. No single cable length or thickness will work for all applications.

- Keep cables with the same current direction away from each other (*Figure 6*)
- Avoid loops or windows
- Twist cables of opposing currents in order to minimize the magnetic flux which will in turn reduce the reactance
- Utilize higher open circuit voltages when available

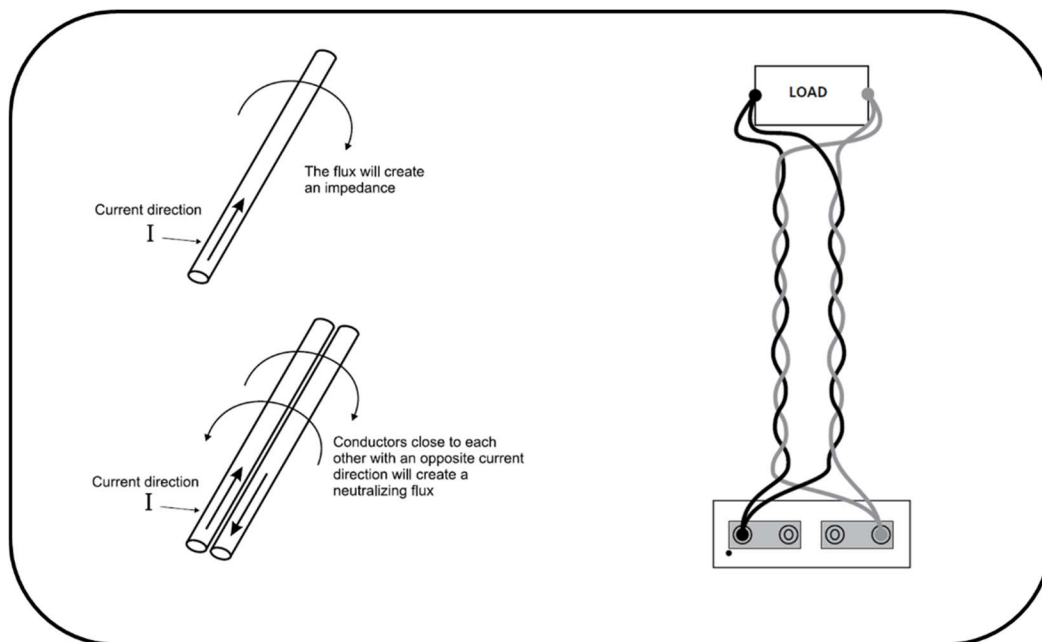

*(Figure 6) Avoid Loops or “windows”. When resistance is low, the major part of the impedance is caused by the reactance. Minimizing the magnetic flux will reduce the reactance. Cables of opposing currents can be twisted together over the length of the cable to minimize the flux.*

## APPLICATION NOTE

### Ground Fault Protection Testing per NEC 230.95(C) of Low Voltage Circuit Breakers

#### References:

- 1.) "Performance Testing for Ground Fault Circuit Breakers." Eaton Instruction Leaflet IL012125EN, 2018.
- 2.) "Field Testing and Maintenance Guide for Thermal-Magnetic and Micrologic Electronic-Trip Circuit Breakers." *Schneider Electric Instruction Bulletin 0600IB1201*, 2013.
- 3.) "Ground-Fault Protection for Solidly Grounded Low-Voltage Systems." *General Electric Application Engineering Information GET-6533A 0691BLE*, 1991.
- 4.) *Standard for Maintenance Testing Specifications for Electrical Power Equipment and Systems*. NETA, 2019.
- 5.) "NFPA70 National Electric Code." *Article 230.95*, 2017.
- 6.) "Pure Sine Wave vs. Modified Sine Wave Inverters- What's the Difference?" *Solar Power News & DIY Solar Tips*, 27 Oct. 2015